

## Driver Manual

# FS-8700-125 Stulz

### **APPLICABILITY & EFFECTIVITY**

Effective for all systems manufactured after March 2021.



Driver Revision: 1.01  
Document Revision: 3.A



**fieldserver**

MSA Safety  
1991 Tarob Court  
Milpitas, CA 95035  
Website: [www.MSAsafety.com](http://www.MSAsafety.com)

U.S. Support Information:  
+1 408 964-4443  
+1 800 727-4377  
Email: [smc-support@msasafety.com](mailto:smc-support@msasafety.com)

EMEA Support Information:  
+31 33 808 0590  
Email: [smc-support.emea@msasafety.com](mailto:smc-support.emea@msasafety.com)

## Contents

<b>1</b>	<b>Description</b> .....	<b>4</b>
<b>2</b>	<b>Hardware Connections</b> .....	<b>5</b>
	2.1 Hardware Connection Tips / Hints.....	5
<b>3</b>	<b>Data Array Parameters</b> .....	<b>6</b>
<b>4</b>	<b>Client Side Configuration</b> .....	<b>7</b>
	4.1 Client Side Connection Parameters .....	7
	4.2 Client Side Node Descriptors .....	8
	4.3 Client Side Map Descriptor Parameters .....	8
	4.3.1 FieldServer Specific Map Descriptor Parameters .....	8
	4.3.2 Driver Related Map Descriptor Parameters .....	8
	4.4 Map Descriptor Examples .....	9
	4.4.1 The Active Read Command .....	9
	4.4.2 Float and Integer Passive Commands .....	9
	4.4.3 Bit Array Passive Commands .....	9
<b>5</b>	<b>Stulz Commands</b> .....	<b>10</b>
<b>6</b>	<b>Troubleshooting</b> .....	<b>16</b>

## 1 Description

The Stulz driver allows the transfer of data from a Stulz device using the Stulz monitoring protocol version 1.7. The FieldServer can act as a Client.

Currently, only the C6000 microcontroller is supported as the protocol only specifies read capabilities on that unit.

The Client is configurable to read all information into separate data points and supports writing to selected points as specified below.

There is support for the following formats:

- Float values
- Binary values
- Integer values

### Max Nodes Supported

FieldServer Mode	Nodes	Comments
Client	32	The protocol supports one Client per system, but 32 devices can be read on the system.

## 2 Hardware Connections

The FieldServer is connected to the Stulz device over RS-485 as shown in the connection drawings below.

**NOTE: Configure the Stulz C6000 according to the manufacturer's instructions.**

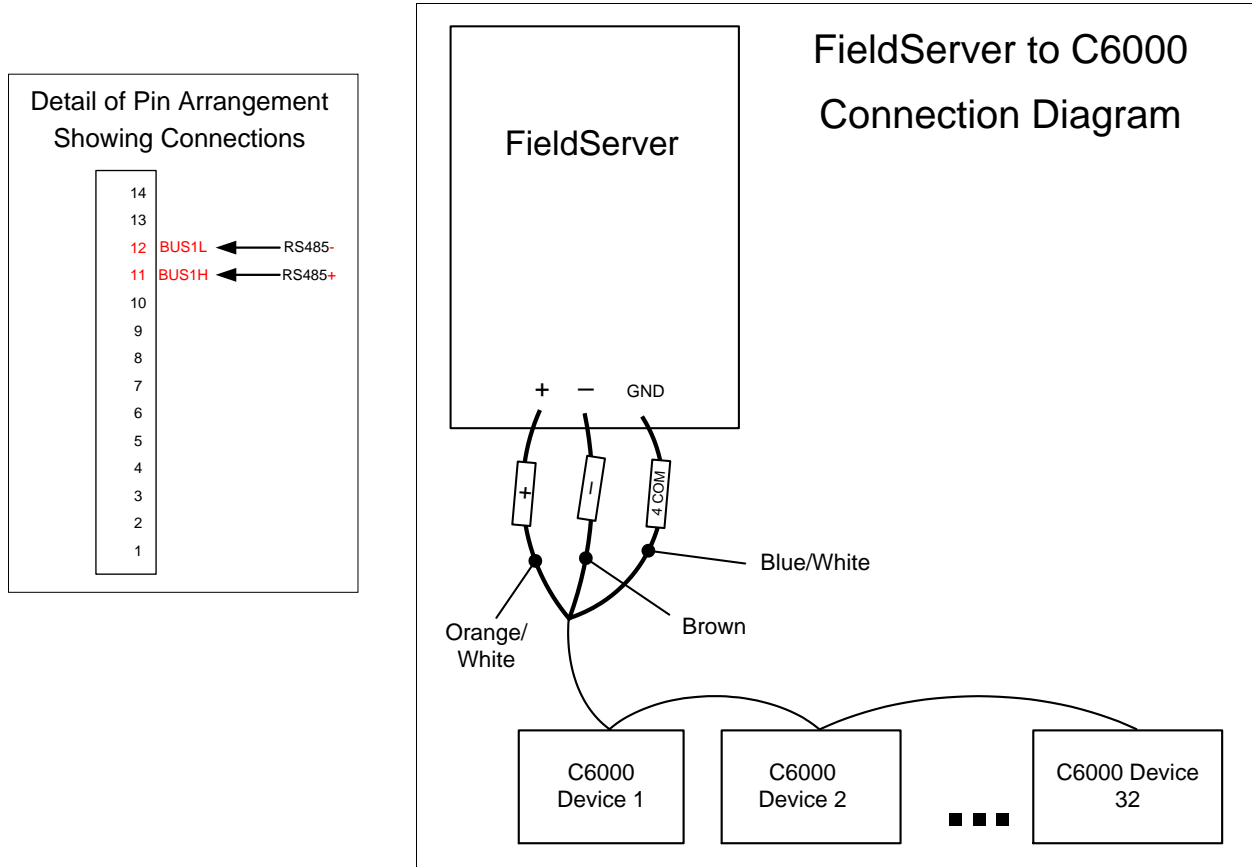

### 2.1 Hardware Connection Tips / Hints

- Connect the wire to bus 1 on the Stulz device. Make sure that bus 1 is used as bus 2 is used by the device to communicate with its IO devices.
- Use shielded twisted pair wire to make connections.
- Use terminating resistors. The Stulz device has terminating resistors which are set with a jumper.
- Make sure that line is terminated at both ends to ensure maximum communication efficiency.
- For C6000 controller information, email Stulz at [STULZTechnicalSupport@stulz-ats.com](mailto:STULZTechnicalSupport@stulz-ats.com).

## 3 Data Array Parameters

Data Arrays are “protocol neutral” data buffers for storage of data to be passed between protocols. It is necessary to declare the data format of each of the Data Arrays to facilitate correct storage of the relevant data.

Section Title		
Data_Arrays		
Column Title	Function	Legal Values
Data_Array_Name	Provide name for Data Array.	Up to 15 alphanumeric characters
Data_Array_Format	Provide data format. Each Data Array can only take on one format.	Float, Bit, Byte, UInt16, UInt32, Sint16, Sint32
Data_Array_Length	Number of Data Objects. Must be larger than the data storage area required by the Map Descriptors for the data being placed in this array.	1-10000

### Example

```
// Data Arrays
Data_Arrays
Data_Array_Name , Data_Array_Format , Data_Array_Length
DA_AI_01 , UInt16 , 200
DA_AO_01 , UInt16 , 200
DA_DI_01 , Bit , 200
DA_DO_01 , Bit , 200
```

## 4 Client Side Configuration

For detailed information on FieldServer configuration, refer to the FieldServer Configuration Manual. The information that follows describes how to expand upon the factory defaults provided in the configuration files included with the FieldServer (see “.csv” files provided with the FieldServer).

This section documents and describes the parameters necessary for configuring the FieldServer to communicate with a Stulz microcontroller device.

The configuration file tells the FieldServer about its interfaces, and the routing of data required. In order to enable the FieldServer for Stulz communications, the driver independent FieldServer buffers need to be declared in the “Data Arrays” section, the FieldServer virtual node(s) needs to be declared in the “Nodes” section, and the data to be provided to the Clients’ needs to be mapped in the “Map Descriptors” section. Details on how to do this can be found below.

**NOTE:** In the tables below, \* indicates an optional parameter, with the bold legal value as default.

### 4.1 Client Side Connection Parameters

Section Title		
Connections		
Column Title	Function	Legal Values
Port	Specify which port the device is connected to the FieldServer.	P1-P2, R1-R2 <sup>1</sup>
Protocol	Specify protocol used.	Stulz
Baud*	Specify baud rate.	<b>9600</b> – The baud rate is limited by the Stulz bus being only 9600
Parity*	Specify parity.	<b>None</b>
Data_Bits*	Specify data bits.	<b>8</b>
Stop_Bits*	Specify stop bits.	<b>1</b>
Poll_Delay*	Time between internal polls.	0-32000 seconds, <b>0.05 seconds</b>

#### Example

```
// Client Side Connections
Connections
Port , Protocol , Baud , Parity , Poll_Delay
R1 , STULZ , 9600 , None , 0.100s
```

<sup>1</sup> Not all ports shown may be supported by the hardware. Consult the appropriate Instruction manual for details of the hardware.

## 4.2 Client Side Node Descriptors

Section Title		
Nodes		
Column Title	Function	Legal Values
Node_Name	Provide name for node.	Up to 32 alphanumeric characters
Node_ID	Modbus station address of physical Server node.	1-32
Protocol	Specify protocol used.	Stulz
Connection	Specify through which port the device is connected to the FieldServer.	P1-P2, R1-R2 <sup>1</sup>

### Example

```
// Client Side Nodes
Nodes
Node_Name , Node_ID , Protocol , Connection
SATS1 ,1 , Stulz , R1
```

## 4.3 Client Side Map Descriptor Parameters

### 4.3.1 FieldServer Specific Map Descriptor Parameters

Column Title	Function	Legal Values
Map_Descriptor_Name	Name of this Map Descriptor.	Up to 32 alphanumeric characters
Data_Array_Name	Name of Data Array where data is to be stored in the FieldServer.	One of the Data Array names from "Data Array" section above
Data_Array_Offset	Starting location in Data Array.	0 to maximum specified in "Data Array" section above
Function	Function of Server Map Descriptor.	RDBC, WRBX, WRBC, Passive_client
Scan_Interval	Buffers Update Period.	> 0.001s

### 4.3.2 Driver Related Map Descriptor Parameters

Column Title	Function	Legal Values
Node_Name	Name of Node to fetch data from.	One of the node names specified in "Client Node Descriptor" above
Length	Length of Map Descriptor.	When using PASSIVE_CLIENT function, length is 1; For Active Map Descriptors use a length up to 232, depending on command
Stulz_Command	Specifies the command to be read from the device. In order to read data a legal LS command is needed.	Specified in <b>Section 5</b>



## 4.4 Map Descriptor Examples

### 4.4.1 The Active Read Command

```
// Client Side Map Descriptors
Map_Descriptors
Map_Descriptor_Name , Data_Array_Name , Data_Array_Offset , Function , Node_Name
Active_Read , DA_ACTIVE , 0 , RDBC , Node_A

, Stulz_Command , Length , Scan_Interval
, ls , 1 , 5
```

#### Example comments:

- Data\_Array\_Name – The ls command should point to a Data Array of type Byte.
- Function – On the ls command, use RDBC (for continuous reading) or RDB for once-off reading.
- Stulz\_Command – In order to read any data, a ls command with a RDBC is required. Every time it is read, the data will be stored according to the passive Clients.
- Length – Use length 1 for the ls command.

### 4.4.2 Float and Integer Passive Commands

```
// Client Side Map Descriptors
Map_Descriptors
Map_Descriptor_Name , Data_Array_Name , Data_Array_Offset , Function , Node_Name
A1 , DA_AI3 , 0 , Passive_Client , Node_A

, Stulz_Command , Length , Scan_Interval
, sett , 1 , 5
```

#### Example comments:

- Data\_Array\_Name – This Data Array is where the data will be stored and to which a write can be performed (if it is supported – see **Section 5**).
- Function – These commands must always be passive (for read-only) or passive-Client (for read and write) or WRBX (write only). RDBC is not supported for these commands.
- Length – The length for these commands must always be 1.

### 4.4.3 Bit Array Passive Commands

```
// Client Side Map Descriptors
Map_Descriptors
Map_Descriptor_Name , Data_Array_Name , Data_Array_Offset , Function , Node_Name
B1 , DA_BI3 , 0 , Passive_Client , Node_A

, Stulz_Command , Length , Scan_Interval
, gst1 , 1 , 5
```

#### Example comments:

- Data\_Array\_Name – Bit array commands must point to Uint16 Data Array for easiest use.
- Data\_Array\_Offset – The offset should point to the first bit of a byte i.e. 0, 8, 16, 24, etc. These commands use 8 bit spaces in this array.
- Function – These commands must always be passive (for read-only) or passive-Client (for read and write) or WRBX (write only). RDBC is not supported for these commands.
- Length – The length for these commands must always be 1.

5 Stulz Commands

FieldServer as a Client						
Command	Description	Data Type	Signed	Range	Units	C6000
<b>Active Commands</b>						
ls	Long state request	Byte	N	-		r
m1fss	Module 1 fan speed setpoint	Integer	N	0..100	%	r/w
m2fss	Module 2 fan speed setpoint	Integer	N	0..100	%	r/w
m3fss	Module 3 fan speed setpoint	Integer	N	0..100	%	r/w
m4fss	Module 4 fan speed setpoint	Integer	N	0..100	%	r/w
m5fss	Module 5 fan speed setpoint	Integer	N	0..100	%	r/w
m6fss	Module 6 fan speed setpoint	Integer	N	0..100	%	r/w
m1dcsst	Module 1 drycooler summer start	Integer	N	0..50	C	r/w
m1dcwst	Module 1 drycooler winter start	Integer	N	0..30	C	r/w
m2dcsst	Module 2 drycooler summer start	Integer	N	0..50	C	r/w
m2dcwst	Module 2 drycooler winter start	Integer	N	0..30	C	r/w
m3dcsst	Module 3 drycooler summer start	Integer	N	0..50	C	r/w
m3dcwst	Module 3 drycooler winter start	Integer	N	0..30	C	r/w
m4dcsst	Module 4 drycooler summer start	Integer	N	0..50	C	r/w
m4dcwst	Module 4 drycooler winter start	Integer	N	0..30	C	r/w
m5dcsst	Module 5 drycooler summer start	Integer	N	0..50	C	r/w
m5dcwst	Module 5 drycooler winter start	Integer	N	0..30	C	r/w
m6dcsst	Module 6 drycooler summer start	Integer	N	0..50	C	r/w
m6dcwst	Module 6 drycooler winter start	Integer	N	0..30	C	r/w
ssat	Setpoint Supply Air Temperature	Float	N	10..35	C	r/w
ssah	Setpoint Supply Air Humidity	Integer	N	0..100	%	r/w
ssrt	Setpoint Room Temperature	Float	N	10..35	C	r/w
ssrt	Setpoint Room Humidity	Integer	N	0..100	%	r/w
hpdsc	HP DSC Function	Integer	N	0 – DSCwFS 1 – Stulz 2 - DSC	-	r/w
gcwmode	G/CW mode	Byte		0..1	-	r/w
cwsel	Remote CW selector	Byte		0..1	-	r/w
rfs1	Read Fan Speed 1	Float	N	0..100	%	r/w
rfs2	Read Fan Speed 2	Float	N	0..100	%	r/w
rfs3	Read Fan Speed 3	Float	N	0..100	%	r/w
<b>Passive Client Commands</b>						
wt	Water temperature	Float	Y	-50..50	C	r
rat	Return air temperature	Float	N	0..100	C	r
sat	Supply air temperature	Float	N	0..100	C	r
rah	Return air humidity	Float	N	0..100	%	r
sah	Supply air humidity	Float	N	0..100	%	r
oat	Outside air temperature	Float	Y	-50..50	C	r
oah	Outside air humidity	Float	N	0..100	%	r
tss	Temperature set point shift	Float	Y	-12.7..12.7	C	r
hss	Humidity set point shift	Float	Y	-12.7..12.7	%	r
swv	Software version					r
m1o1	Module 1 digital out status byte 1	UInt16				r
0	Reheat 1	Bit				r
1	Compressor 1	Bit				r
2	Humidification 1	Bit				r
3	Dehumidification 1	Bit				r
4	Fan 1	Bit				r
5	Dry cooler	Bit				r
6	Alarm relays 1 (1= no alarm)	Bit				r
7	PWV	Bit				r
m1o2	Module 1 digital out status byte 2	UInt16				r
0	Reheat 2	Bit				r
1	Glycol pump	Bit				r

FieldServer as a Client						
Command	Description	Data Type	Signed	Range	Units	C6000
2	Louver (0=closed, 1=open)	Bit				r
3	Alarm relays 2 (1= no alarm)	Bit				r
4	Alarm relays 3 (1= no alarm)	Bit				r
5	Alarm relays 4 (1= no alarm)	Bit				r
6	Alarm relays 5 (1= no alarm)	Bit				r
7	Glycol pump 1/2 select	Bit				r
m2o1 <sup>2</sup>	Module 2 digital out status byte 1	Uint16				r
m2o2 <sup>3</sup>	Module 2 digital out status byte 2	Uint16				r
m3o1 <sup>2</sup>	Module 3 digital out status byte 1	Uint16				r
m3o2 <sup>3</sup>	Module 3 digital out status byte 2	Uint16				r
m4o1 <sup>2</sup>	Module 4 digital out status byte 1	Uint16				r
m4o2 <sup>3</sup>	Module 4 digital out status byte 2	Uint16				r
m5o1 <sup>2</sup>	Module 5 digital out status byte 1	Uint16				r
m5o2 <sup>3</sup>	Module 5 digital out status byte 2	Uint16				r
m6o1 <sup>2</sup>	Module 6 digital out status byte 1	Uint16				r
m6o2 <sup>3</sup>	Module 6 digital out status byte 2	Uint16				r
m1i1	Module 1 digital in status byte 1	Uint16				r
0	Compressor low pressure	Bit				r
1	Compressor high pressure	Bit				r
2	Reheat 1 failure	Bit				r
3	Humidification failure	Bit				r
4	Air flow failure	Bit				r
5	Filter clogged	Bit				r
6	Aux alarm 1	Bit				r
7	Reheat 2 alarm	Bit				r
m1i2	Module 1 digital in status byte 2	Uint16				r
0	Conductivity too high	Bit				r
1	Ultrasonic failure	Bit				r
2	Glycol pump 1 failure	Bit				r
3	Glycol pump 2 failure	Bit				r
4	Drycooler failure	Bit				r
5	Water detector	Bit				r
6	Aux alarm 2	Bit				r
7	Aux alarm 3	Bit				r
m2i1 <sup>4</sup>	Module 2 digital in status byte 1	Uint16				r
m2i2 <sup>5</sup>	Module 2 digital in status byte 2	Uint16				r
m3i1 <sup>4</sup>	Module 3 digital in status byte 1	Uint16				r
m3i2 <sup>5</sup>	Module 3 digital in status byte 2	Uint16				r
m4i1 <sup>4</sup>	Module 4 digital in status byte 1	Uint16				r
m4i2 <sup>5</sup>	Module 4 digital in status byte 2	Uint16				r
m5i1 <sup>4</sup>	Module 5 digital in status byte 1	Uint16				r
m5i2 <sup>5</sup>	Module 5 digital in status byte 2	Uint16				r
m6i1 <sup>4</sup>	Module 6 digital in status byte 1	Uint16				r
m6i2 <sup>5</sup>	Module 6 digital in status byte 2	Uint16				r
m1gecw	Module 1 analogue out GE/CW	Float	N	0..100		r
m2gecw	Module 2 analogue out GE/CW	Float	N	0..100		r
m3gecw	Module 3 analogue out GE/CW	Float	N	0..100		r
m4gecw	Module 4 analogue out GE/CW	Float	N	0..100		r
m5gecw	Module 5 analogue out GE/CW	Float	N	0..100		r
m6gecw	Module 6 analogue out GE/CW	Float	N	0..100		r
m1pww	Module 1 analogue out PWW	Float	N	0..100		r
m2pww	Module 2 analogue out PWW	Float	N	0..100		r

<sup>2</sup> These commands' structure match the m1o1 structure.

<sup>3</sup> These commands' structure match the m1o2 structure.

<sup>4</sup> These commands' structure match the m1i1 structure.

<sup>5</sup> These commands' structure match the m1i2 structure.

FieldServer as a Client						
Command	Description	Data Type	Signed	Range	Units	C6000
m3pww	Module 3 analogue out PWW	Float	N	0..100		r
m4pww	Module 4 analogue out PWW	Float	N	0..100		r
m5pww	Module 5 analogue out PWW	Float	N	0..100		r
m6pww	Module 6 analogue out PWW	Float	N	0..100		r
m1aoh	Module 1 analogue out humidifier	Float	N	0..100		r
m2aoh	Module 2 analogue out humidifier	Float	N	0..100		r
m3aoh	Module 3 analogue out humidifier	Float	N	0..100		r
m4aoh	Module 4 analogue out humidifier	Float	N	0..100		r
m5aoh	Module 5 analogue out humidifier	Float	N	0..100		r
m6aoh	Module 6 analogue out humidifier	Float	N	0..100		r
m1aosv	Module 1 analogue out suction valve	Float	N	0..100		r
m2aosv	Module 2 analogue out suction valve	Float	N	0..100		r
m3aosv	Module 3 analogue out suction valve	Float	N	0..100		r
m4aosv	Module 4 analogue out suction valve	Float	N	0..100		r
m5aosv	Module 5 analogue out suction valve	Float	N	0..100		r
m6aosv	Module 6 analogue out suction valve	Float	N	0..100		r
m16doc2	Module 1-6 digital out compressor 2	UInt16				r
0	Module 1 compressor 2	Bit				r
1	Module 2 compressor 2	Bit				r
2	Module 3 compressor 2	Bit				r
3	Module 4 compressor 2	Bit				r
4	Module 5 compressor 2	Bit				r
5	Module 6 compressor 2	Bit				r
6	Not used	Bit				r
7	Not used	Bit				r
m14dic2	Module 1-4 digital in compressor 2	UInt16				r
0	modul 1 compressor 2 low pressure	Bit				r
1	modul 1 compressor 2 high pressure	Bit				r
2	modul 2 compressor 2 low pressure	Bit				r
3	modul 2 compressor 2 high pressure	Bit				r
4	modul 3 compressor 2 low pressure	Bit				r
5	modul 3 compressor 2 high pressure	Bit				r
6	modul 4 compressor 2 low pressure	Bit				r
7	modul 4 compressor 2 high pressure	Bit				r
m56dic2	Module 5-6 digital in compressor 2	UInt16				r
0	modul 5 compressor 2 low pressure	Bit				r
1	modul 5 compressor 2 high pressure	Bit				r
2	modul 6 compressor 2 low pressure	Bit				r
3	modul 6 compressor 2 high pressure	Bit				r
4	not used	Bit				r
5	not used	Bit				r
6	not used	Bit				r
7	not used	Bit				r
sett	Setpoint temperature	Float	N	10..35	C	r/w
seth	Setpoint humidity	Integer	N	10..90	%	r/w
year	Date – Year	Integer	N	0..99		r/w
month	Date – Month	Integer	N	1..12		r/w
day	Date – Day	Integer	N	1..31		r/w
hour	Time – Hour	Integer	N	0..23		r/w
minute	Time – Minute	Integer	N	0..59		r/w
ratha	Return air temperature too high alarm	Integer	N	0..30	C	r/w
satha	Supply air temperature too high alarm	Integer	N	0..30	C	r/w
ratla	Return air temperature too low alarm	Integer	N	0..30	C	r/w
satla	Supply air temperature too low alarm	Integer	N	0..30	C	r/w
wtha	Water temperature too high alarm	Integer	N	0..50	C	r/w
wtla	Water temperature too low alarm	Integer	Y	-50..30	C	r/w
rahha	Return air humidity too high alarm	Integer	N	0..90	%	r/w

FieldServer as a Client						
Command	Description	Data Type	Signed	Range	Units	C6000
sahha	Supply air humidity too high alarm	Integer	N	0..90	%	r/w
rahla	Return air humidity too low alarm	Integer	N	0..90	%	r/w
sahla	Supply air humidity too low alarm	Integer	N	0..90	%	r/w
Module 1						
1comps	Compressor start	Float	N	0..10		r/w
1comph	Compressor hysteresis	Float	N	0..10		r/w
1svst	Suction valve start	Float	N	0..10		r/w
1svpb	Suction valve proportional ban	Float	N	0..10		r/w
1drycst	Drycooler start temperature	Integer	N	0..45		r
1drycet	Drycooler enable temperature	Integer	N	0..45		r
1gpst	Glycol-pump start temperature	Integer	N	0..100		r/w
1gecwvo	GE/CW valve off temperature	Integer	N	0..35	C	r/w
1gecwvs	GE/CW valve start temperature	Integer	N	0..10		r/w
1gecwvpb	GE/CW valve proportional band	Float	N	0..10		r/w
1r1st	Reheat 1 start temperature	Float	N	0..10		r/w
1r1h	Reheat 1 hysteresis	Float	N	0..10		r/w
1r2st	Reheat 2 start temperature	Float	N	0..10		r/w
1r2h	Reheat 2 hysteresis	Float	N	0..10		r/w
1r3st	Reheat 3 start temperature	Float	N	0..10		r/w
1r3h	Reheat 3 hysteresis	Float	N	0..10		r/w
1pwwvs	PWW valve start temperature	Float	N	0..10		r/w
1pwwvpb	PWW valve proportional band	Float	N	0..10		r/w
1dhs	Dehumidification start	Integer	N	0..90		r/w
1dhh	Dehumidification hysteresis	Integer	N	0..90		r/w
1hums	Humidification start	Integer	N	0..90		r/w
1humh	Humidification hysteresis	Integer	N	0..90		r/w
1humsa	Humidification start (analogue)	Integer	N	0..90		r/w
1humpba	Humidification proportional band	Integer	N	0..90		r/w
1gcph	Glycol-pump hysteresis	Integer	N	0..10		r/w
Module 2						
2comps	Compressor start	Float	N	0..10		r/w
2comph	Compressor hysteresis	Float	N	0..10		r/w
2svst	Suction valve start	Float	N	0..10		r/w
2svpb	Suction valve proportional ban	Float	N	0..10		r/w
2drycst	Drycooler start temperature	Integer	N	0..45	C	r
2r1st	Reheat 1 start temperature	Float	N	0..10		r/w
2r1h	Reheat 1 hysteresis	Float	N	0..10		r/w
2r2st	Reheat 2 start temperature	Float	N	0..10		r/w
2r2h	Reheat 2 hysteresis	Float	N	0..10		r/w
2r3st	Reheat 3 start temperature	Float	N	0..10		r/w
2r3h	Reheat 3 hysteresis	Float	N	0..10		r/w
2dhs	Dehumidification start	Integer	N	0..90	%	r/w
2dhh	Dehumidification hysteresis	Integer	N	0..90	%	r/w
2hums	Humidification start	Integer	N	0..90	%	r/w
2humh	Humidification hysteresis	Integer	N	0..90	%	r/w
2humsa	Humidification start (analogue)	Integer	N	0..90	%	r/w
2humpba	Humidification proportional band	Integer	N	0..90	%	r/w
2gecwvs	GE/CW valve start temperature	Float	N	0..10		r/w
2gecwvpb	GE/CW valve proportional band	Float	N	0..10		r/w
Module 3						
3comps	Compressor start	Float	N	0..10		r/w
3comph	Compressor hysteresis	Float	N	0..10		r/w
3svst	Suction valve start	Float	N	0..10		r/w
3svpb	Suction valve proportional ban	Float	N	0..10		r/w
3drycst	Drycooler start temperature	Integer	N	0..45	C	r
3r1st	Reheat 1 start temperature	Float	N	0..10		r/w
3r1h	Reheat 1 hysteresis	Float	N	0..10		r/w

FieldServer as a Client						
Command	Description	Data Type	Signed	Range	Units	C6000
3r2st	Reheat 2 start temperature	Float	N	0..10		r/w
3r2h	Reheat 2 hysteresis	Float	N	0..10		r/w
3r3st	Reheat 3 start temperature	Float	N	0..10		r/w
3r3h	Reheat 3 hysteresis	Float	N	0..10		r/w
3dhs	Dehumidification start	Integer	N	0..90	%	r/w
3dhh	Dehumidification hysteresis	Integer	N	0..90	%	r/w
3hums	Humidification start	Integer	N	0..90	%	r/w
3humh	Humidification hysteresis	Integer	N	0..90	%	r/w
3humsa	Humidification start (analogue)	Integer	N	0..90	%	r/w
3humpba	Humidification proportional band	Integer	N	0..90	%	r/w
3gecwvs	GE/CW valve start temperature	Float	N	0..10		r/w
3gecwvpb	GE/CW valve proportional band	Float	N	0..10		r/w
<b>Module 4</b>						
4comps	Compressor start	Float	N	0..10		r/w
4comph	Compressor hysteresis	Float	N	0..10		r/w
4svst	Suction valve start	Float	N	0..10		r/w
4svpb	Suction valve proportional ban	Float	N	0..10		r/w
4drycst	Drycooler start temperature	Integer	N	0..45	C	r
4r1st	Reheat 1 start temperature	Float	N	0..10		r/w
4r1h	Reheat 1 hysteresis	Float	N	0..10		r/w
4r2st	Reheat 2 start temperature	Float	N	0..10		r/w
4r2h	Reheat 2 hysteresis	Float	N	0..10		r/w
4r3st	Reheat 3 start temperature	Float	N	0..10		r/w
4r3h	Reheat 3 hysteresis	Float	N	0..10		r/w
4dhs	Dehumidification start	Integer	N	0..90	%	r/w
4dhh	Dehumidification hysteresis	Integer	N	0..90	%	r/w
4hums	Humidification start	Integer	N	0..90	%	r/w
4humh	Humidification hysteresis	Integer	N	0..90	%	r/w
4humsa	Humidification start (analogue)	Integer	N	0..90	%	r/w
4humpba	Humidification proportional band	Integer	N	0..90	%	r/w
4gecwvs	GE/CW valve start temperature	Float	N	0..10		r/w
4gecwvpb	GE/CW valve proportional band	Float	N	0..10		r/w
<b>Module 5</b>						
5comps	Compressor start	Float	N	0..10		r/w
5comph	Compressor hysteresis	Float	N	0..10		r/w
5svst	Suction valve start	Float	N	0..10		r/w
5svpb	Suction valve proportional ban	Float	N	0..10		r/w
5drycst	Drycooler start temperature	Integer	N	0..45	C	r
5r1st	Reheat 1 start temperature	Float	N	0..10		r/w
5r1h	Reheat 1 hysteresis	Float	N	0..10		r/w
5r2st	Reheat 2 start temperature	Float	N	0..10		r/w
5r2h	Reheat 2 hysteresis	Float	N	0..10		r/w
5r3st	Reheat 3 start temperature	Float	N	0..10		r/w
5r3h	Reheat 3 hysteresis	Float	N	0..10		r/w
5dhs	Dehumidification start	Integer	N	0..90	%	r/w
5dhh	Dehumidification hysteresis	Integer	N	0..90	%	r/w
5hums	Humidification start	Integer	N	0..90	%	r/w
5humh	Humidification hysteresis	Integer	N	0..90	%	r/w
5humsa	Humidification start (analogue)	Integer	N	0..90	%	r/w
5humpba	Humidification proportional band	Integer	N	0..90	%	r/w
5gecwvs	GE/CW valve start temperature	Float	N	0..10		r/w
5gecwvpb	GE/CW valve proportional band	Float	N	0..10		r/w
<b>Module 6</b>						
6comps	Compressor start	Float	N	0..10		r/w
6comph	Compressor hysteresis	Float	N	0..10		r/w
6svst	Suction valve start	Float	N	0..10		r/w
6svpb	Suction valve proportional ban	Float	N	0..10		r/w

FieldServer as a Client						
Command	Description	Data Type	Signed	Range	Units	C6000
6drycst	Drycooler start temperature	Integer	N	0..45	C	r
6r1st	Reheat 1 start temperature	Float	N	0..10		r/w
6r1h	Reheat 1 hysteresis	Float	N	0..10		r/w
6r2st	Reheat 2 start temperature	Float	N	0..10		r/w
6r2h	Reheat 2 hysteresis	Float	N	0..10		r/w
6r3st	Reheat 3 start temperature	Float	N	0..10		r/w
6r3h	Reheat 3 hysteresis	Float	N	0..10		r/w
6dhs	Dehumidification start	Integer	N	0..90	%	r/w
6dhh	Dehumidification hysteresis	Integer	N	0..90	%	r/w
6hums	Humidification start	Integer	N	0..90	%	r/w
6humh	Humidification hysteresis	Integer	N	0..90	%	r/w
6humsa	Humidification start (analogue)	Integer	N	0..90	%	r/w
6humpba	Humidification proportional band	Integer	N	0..90	%	r/w
6gecwvs	GE/CW valve start temperature	Float	N	0..10		r/w
6gecwvpb	GE/CW valve proportional band	Float	N	0..10		r/w
gst1	General status byte 1	Uint16				
0	0 = PC-STOP (monitoring), 1 = on	Bit				r/w
1	0 = REMOTE STOP (contact), 1 = on	Bit				r
2	0 = LOCAL STOP (key), 1 = on	Bit				r
3	0 = TIMER-STOP (weekly oper.), 1 = on	Bit				r
4	Seq. Start/Stop (0=No, 1=Yes)	Bit				r
5	WARM UP STOP	Bit				r
6	Remote UPS 1 = UPS activ	Bit				r
7	Local UPS 1 = UPS activ	Bit				r
gst2 <sup>6</sup>	General status byte 2	Uint16				
0	G/CW-mode; G:1, CW:0	Bit				r/w
1	CW-Valve OR/AND – selector	Bit				r
2	not used					
3	not used					
4	not used					
5	not used					
6	not used					
7	not used					
err1	Error byte 1	Uint16				
0	return air temp. too high alarm	Bit				r
1	return air humid. Too high alarm	Bit				r
2	supply air temp. too high alarm	Bit				r
3	supply air humid. Too high alarm	Bit				r
4	water temp. too high alarm	Bit				r
5	return air temp. too low alarm	Bit				r
6	return air humid. Too low alarm	Bit				r
7	supply air temp. too low alarm	Bit				r
err2	Error byte 2	Uint16				
0	supply air humid. Too low alarm	Bit				r
1	water temp. too low alarm	Bit				r
2	supervisor failure	Bit				r
3	freeze alarm	Bit				r
4	fire / smoke detector	Bit				r
5	sensor failure	Bit				r
6	controller failure	Bit				r
7	IO-board transmission failure	Bit				r
ar <sup>7</sup>	Alarm reset	None				w

<sup>6</sup> This command has been replaced by gcwmode and cwsel to enable write on the second bit (V2.66).

<sup>7</sup> Writing any value to this command will reset the alarms on the Stulz unit.

### 6 Troubleshooting

Driver Limitations:

Only the 9600 baud setting is supported by Stulz devices.